

KC RACING JAMESTOWN, MICHIGAN
USA

The contents of this document are provided on a restricted basis and are not to be used in any way detrimental to the interests of KC Racing. Copyright © KC Racing. All rights reserved.

Tolerances +/- .005 [0.13] unless noted
Primary units - inches, metric [mm]

Voltan, Carbon Fiber Center

DATE: KCL 10/10/24

QUANTITY: 1000 PRODUCTIONS: 1000
REV: **B** NAME: **KCR-CFV01**

For repairs or adding parts to the carbon fiber:

Do not use standard CA "Super" Glue it is too brittle
 use a Carbon & Rubber Toughened Cyanoacrylate
 without an accelerator
 we recommend
 Bob Smith Industries IC-2000
 www.bsi-inc.com

Cleaning Carbon Fiber:

Use a gentle cleanser or soap, avoid acidic or harsh chemicals.
 Rinse with water. You will want to dry carbon fiber
 immediately after washing and avoid letting water sit on
 carbon fiber parts until it evaporates. This causes
 hard water spots. Use a soft, microfiber towel to dry your
 parts to avoid scratching the surface.

Fasteners Used:

M2 x 0.4 x 4mm long flathead screws
 with a head diameter of 3mm
 M2 x 0.4 hex nuts

Maximum torque: 1.77 lb-in [0.2Nm]
 No thread lock adhesive is recommended or used.

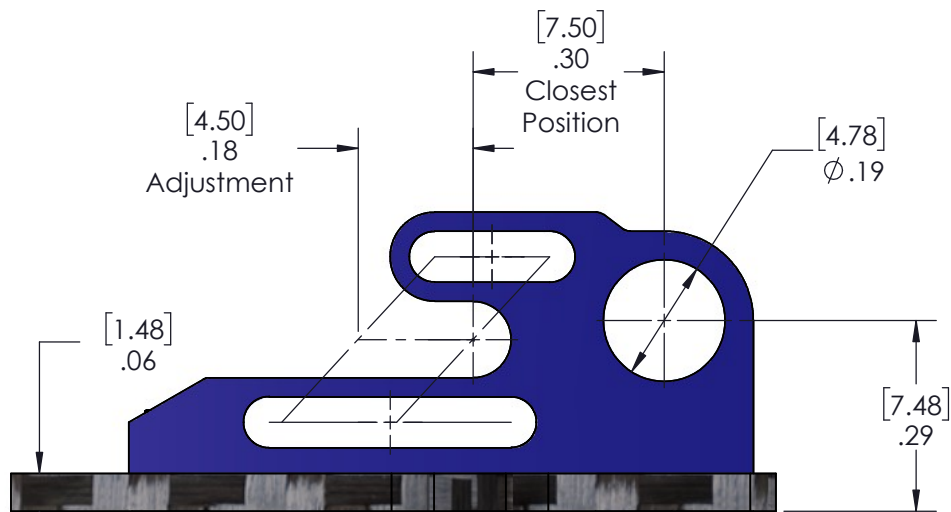

Motor Mount Detail

for gear selection
 designed for 9mm x 9mm mounting
 (Loctite 680 may be used to install
 bearings or bushings into support.)

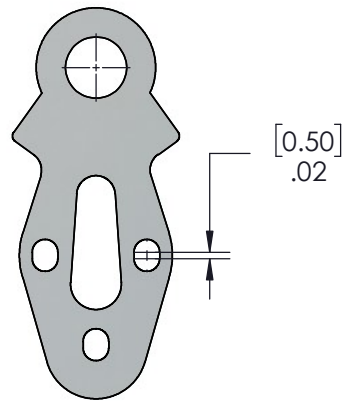

Guide Adjustment
 There is a slight adjustment
 in the guide mount

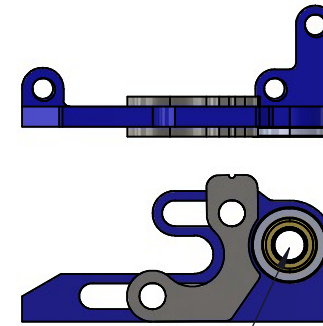

Bearing or bushing
 should be installed
 with Loctite

KCR-CFMS
 As installed
 (optional)

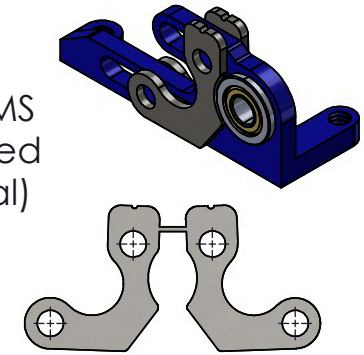

KCR-CFMS
 Motor Spacer
 as purchased

IMPORTANT
BLDC Installation

The motor mount design deployed in the CarbonX chassis
 requires the removal of the motor e-clip and spacer.
 Use of KCR-CFMS between the mount and the motor
 allows the e-clip and spacer to be left installed on the motor.

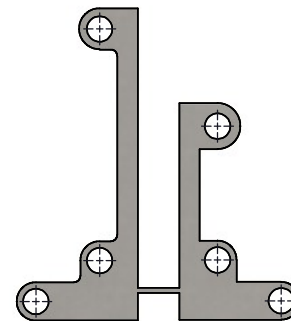

OPTIONAL: KCR-ASM
Rear Axle Shim Kit
 to lower the chassis 0.15" [.381]
 when using large tires

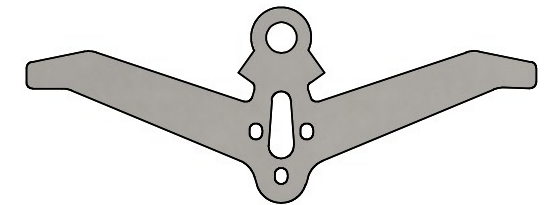
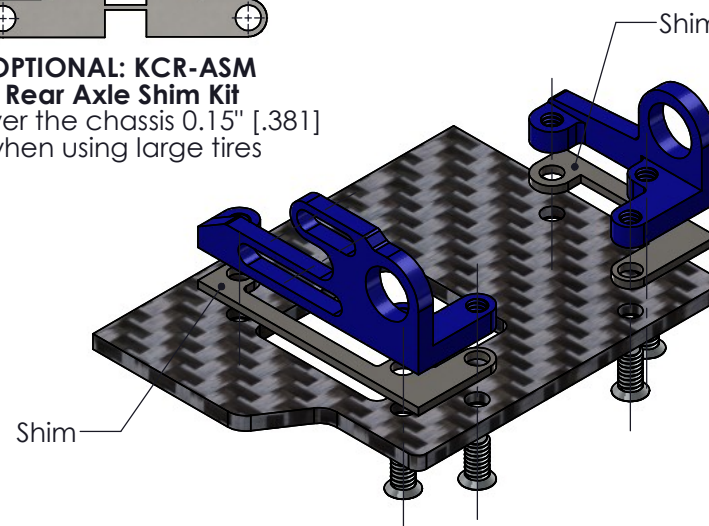

OPTIONAL: KCR-BGB
Guide / Bumper
 used on one piece flexi chassis
 adds 5 grams to chassis front

		JAMESTOWN, MICHIGAN USA	
The contents of this document are provided on a restricted basis and are not to be used in any way detrimental to the interests of KC Racing. Copyright © KC Racing. All rights reserved.			
Tolerances +/- .005 [0.13] unless noted Primary units - inches, metric [mm]			
Carbon Fiber Chassis Supplement			
DATE	REV	ISSUE	VERSION
KCL	10/11/24		
PART NAME / DESCRIPTION		REV	NUMBER
		B	KCR-CF SUP
			SHEET 1 OF 1